

eMOD iMAS923TH

Datasheet

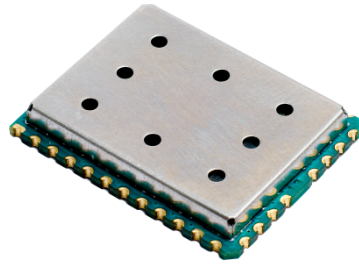

- Document ID: 4100/40140/0119

EmOne (Thailand) Co.,Ltd.

39/1 Soi. Sangkhom Songkhro 12

Lat Phrao, Bangkok 10230 Thailand

EMONE

Document Information

File name	iMAS923TH_Datasheet.odt
Created	2018-04-15
Total pages	xxxii

Revision History

Version	Note
0.1	Created
0.2	Operating modes updated to LoRaWAN
0.3	Corrected output power
0.4	Reviewed
0.5	Added Regulatory Approval Information
0.6	Added Antenna Gain
1.0	Regulatory notice antenna gain and final review
1.1	Updated Table 4 -6
1.1.1	Made Thailand market version

Aim of this Document

The aim of this document is to give a detailed product description including interfaces, features and performance of the radio module iMAS923TH; iM980A.

Table of Contents

- **1. INTRODUCTION**..... IV
 - **1.1 Key Features**
..... iv
 - **1.2 Applications**
..... iv
- **2. MODULE OVERVIEW**..... VI
- **3. LoRA MODULATION TECHNIQUE**..... VIII
 - **3.1 Channel Frequencies**
..... viii
 - **3.2 Data Rates and Spreading Factors**
..... viii
- **4. ELECTRICAL CHARACTERISTICS**..... X
 - **4.1 Absolute Maximum Ratings**
..... X
 - **4.2 Global Electrical Characteristics**
..... xi
 - **4.3 Module Interface Characteristics**
..... xiii
 - **4.4 RF Characteristics**
..... xiv
 - 4.4.1 Applicable Frequency Bands and Sub-Bands
..... xiv
 - 4.4.2 Transmitter RF Characteristics
..... xiv
- **5. MODULE PACKAGE**..... XVI
 - **5.1 Pinout Description**
..... xvi
 - **5.2 Module Dimensions**
..... xxi
 - **5.3 Recommended Footprint**
..... xxi
- **6. MODULE INTERFACE CHARACTERISTICS**..... XXII
 - **6.1 Programming Interface**
..... xxii

-	7. INTEGRATION GUIDE	XXIII
-7.1 Typical Application Schematic	xxiii
-7.2 PCB Design Recommendation	xxiv
-7.3 Recommended Soldering Conditions	xxv
-	8. ORDERING INFORMATION	XXVI
-	9. APPENDIX	XXVII
-9.1 List of Abbreviations	xxvii
-9.2 List of Figures	xxviii
-	10. REGULATORY COMPLIANCE INFORMATION	XXX
-10.1 FCC Regulatory Notices	xxx
-	11. IMPORTANT NOTICE	XXXIII
-11.1 Disclaimer	xxxiii
-11.2 Contact Information	xxxiii

1. Introduction

The iMAS923TH; iM980A is a compact, low power, bidirectional radio module for the 923 MHz frequency band using Semtech's LoRa™ modulation technology. The module provides ultra-long range spread spectrum communication and high interference immunity whilst minimising current consumption. Using the iMAS923TH; iM980A in an application minimizes the need for an expensive and time-consuming RF development. Fast time to market is possible with this pre-qualified module.

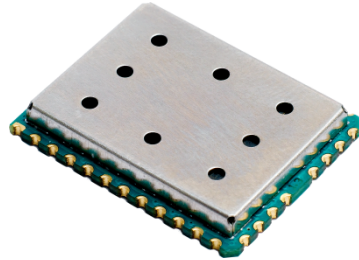

Figure 1-1: Picture of iMAS923TH; iM980A

1.1 Key Features

- Compact module 20.0 x 25.0 x 3.3 mm
- LoRa™ modulation technology
- Sensitivity down to -138 dBm
- UART, SPI and I²C interface¹
- Digital inputs and outputs
- Analog inputs
- Supply voltage range from 2.4 to 3.6 V
- RF interface optimized to 50 Ω
- Integrated 20 dBm Power Amplifier

1.2 Applications

- Automated Meter Reading
- Wireless Networks
- Home-, Building-, Industrial automation
- Remote Control
- Wireless Sensors
- Telemetry
- Wireless Alarm and Security Systems
- ...

¹Default host controller interface is UART. SPI and I²C functionality available on request.

- eMOD iMAS923TH

- High link budget up to 155 dB
- Range up to 15000m (Line of Sight)
- STM32L151CxU6Axx
- Certified according to FCC ID: N/A,
- NBTC TS. 1033-2560

Please visit our web site www.emone.co.th for more information.

2. Module Overview

The iMAS923TH; iM980A is an ultra-long range, high-performance, pre-certified module for wireless communication. It operates in the license free 923 MHz ISM frequency band and includes all necessary passive components for wireless communication as depicted in the following figure.

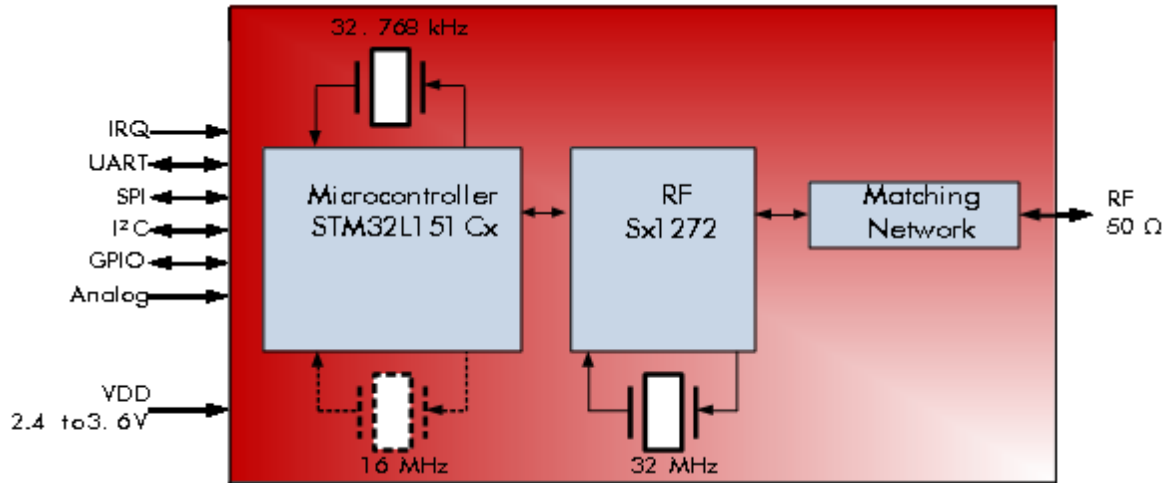

Figure 2-2: Block Diagram of Radio Module iMAS923TH; iM980A

The iMAS923TH; iM980A uses Semtech's patented LoRa modulation technique which combines spread spectrum modulation and forward error correction techniques to increase the range and robustness of radio communication links compared with traditional FSK or OOK based modulation. Typically examples of iMAS923TH receive performances are given in the following table.

Signal Bandwidth/[kHz]	Spreading Factor	Sensitivity/[dBm]
125	7	-123.2
125	12	-137.5
250	7	-120.7
250	12	-134.6
500	7	-115.5
500	12	-130.3

Table 2-1: Typically Radio Performance of iMAS923TH; iM980A

This high sensitivity combined with the integrated power amplifier yields industry leading link budget.

The module is solderable like a SMD component and can easily be mounted on a simple carrier board with a minimum of required external connections. It is RoHS compliant and qualified in accordance to FCC Part 15.

3. LoRa Modulation Technique

The iMAS923TH; iM980A uses Semtech’s LoRa proprietary spread spectrum modulation technique. This modulation, in contrast to conventional modulation techniques, permits an increase in link budget and increased immunity to in-band interference. It achieves sensitivities 8 dB better than FSK modulation.

LoRa also provides significant advantages in both blocking and selectivity, solving the traditional design compromise between range, interference immunity and energy consumption.

3.1 Channel Frequencies

The iMAS923TH; iM980A uses the following channel set up specified by LoRaWAN [2]:

- Uplink (Tx) – 2 channels numbered 0 to 1 utilizing LoRa 125 kHz BW varying from DR0 to DR5, using coding rate 4/5, starting at 923.2 MHz and incrementing linearly by 200 kHz to 923.4 MHz
- Downlink (Rx) – 2 channels numbered 0 to 1 utilizing LoRa 125 kHz BW varying from DR0 to DR5, using coding rate 4/5, starting at 923.2 MHz and incrementing linearly by 200 kHz to 923.4 MHz
- Downlink (Rx) – 1 channels numbered 2 utilizing LoRa 125 kHz BW at DR2, starting at 923.2 MHz

3.2 Data Rates and Spreading Factors

The iMAS923TH; iM980A uses the following data rates and spreading factors specified by LoRaWAN [2]:

Data Rate	Settings	Indicative Physical Bit Rate [bit/s]
-----------	----------	--------------------------------------

0	LoRa: SF12 / 125 kHz	250
1	LoRa: SF11 / 125 kHz	440
2	LoRa: SF10 / 125 kHz	980
3	LoRa: SF9 / 125 kHz	1760
4	LoRa: SF8 / 125 kHz	3125
5	LoRa: SF7 / 125 kHz	5470
6	LoRa: SF7 / 250 kHz	11000
7	FSK: 50 kbps	50000
8:10	For future use	-
11	For future use	-
12	For future use	-
13	For future use	-
14:15	For future use	-

Table 3-2: Data Rates and Spreading Factors

4. Electrical Characteristics

In the following different electrical characteristics of the iMAS923TH; iM980A are listed. Furthermore details and other parameter ranges are available on request.

Note: Stress exceeding of one or more of the limiting values listed under “Absolute Maximum Ratings” may cause permanent damage to the radio module.

4.1 Absolute Maximum Ratings

Parameter	Condition	Min	Typ.	Max	Unit
Supply Voltage (VDD)		-0.3	-	3.9	V
Storage Temperature		-40	-	+85	°C
Operating Temperature		-40	-	+85	°C
RF Input Power				+10	dBm
ESD (Human Body Model)			2000		V
ESD (Charge Device Model)			500		V
Notes:					
1) Unless otherwise noted, all voltages are with respect to GND					

Table 4-3: Absolute Maximum Ratings

Note: With RF output power level above +16 dBm a minimum distance between two devices should be 1 m for avoiding too large input level.

4.2 Global Electrical Characteristics

T = 25°C, VDD = 3.0 V (typ.) if nothing else stated

Parameter	Condition	Min	Typ.	Max	Unit
Supply Voltage (VDD)		2.4	3.0	3.6	V
Current Consumption Low Power Mode	RTC off		800		nA
	RTC on		1.85		µA
Current Consumption System IDLE	TRX idle mode, µC idle mode		5		mA
Current Consumption RECEIVE LoRa @500kHz	TRX receive mode, µC sleep mode		13.2		mA
Current Consumption TRANSMIT	TRX transmit mode, µC sleep mode, all µC units off, max. RF power level		122		mA
MCU operation frequency			32		MHz
			32.768		kHz
Memory (Flash)	iMAS923TH		128		kByte
Flash Memory Endurance	Program memory	10k			Erase/ Write Cycles
	Data memory	300k			
Memory (RAM)	iMAS923TH		32		kByte

Table 4-4: General Characteristics

-

-

4.3 Module Interface Characteristics

T = 25°C, VDD = 3 V (typ.) if nothing else stated

Parameter	Condition	Min	Typ.	Max	Unit
Digital output voltage (high level)	2.4 V < VDD < 2.7V, 4mA (max)	VDD-0.45	-	-	V
	2.7 V < VDD < 3.6V, 8mA (max)	VDD-0.4			
Digital output voltage (low level)	2.4 V < VDD < 2.7V, 4mA (max)	-	-	0.45	V
	2.7 V < VDD < 3.6V, 8mA (max)	-		0.4	
Digital input voltage (high level)	VDD = 2.4 V to 3.6V, CMOS	0.45 VDD+0.38	-	-	V
	VDD = 2.4 V to 3.6V, CMOS, 5Vtolerant	0.39 VDD+0.59	-	-	V
	BOOT0	0.15 VDD+0.56	-	-	V
Digital input voltage (low level)	VDD = 2.4 V to 3.6V	-	-	0.3 VDD	V
	BOOT0	-	-	0.14 VDD	V
UART baud rate			115.2		kbps
Notes: 1) Unless otherwise noted, all voltages are with respect to GND					

Table 4-5: Module Interface Characteristics

4.4 RF Characteristics

4.4.1 Applicable Frequency Bands and Sub-Bands Please refer to chapter 3.1

4.4.2 Transmitter RF Characteristics

The iMAS923TH has an excellent transmitter performance as given by Table 4 -6. For further details, refer to Figure 4 -3 which gives an overview of RF output power levels versus power level settings and its current consumption with microcontroller in sleep mode.

T = 25°C, VDD = 3 V (typ.), 923 MHz if nothing else stated

Parameter	Condition	Min	Typ.	Max	Unit
Frequency Range		920	-	925	MHz
RF Output Power	923 MHz Band		16		dBm
Modulation Techniques	LoRa®				
TX Frequency Variation vs. Temperature	-40 to +85°C	-	±10	-	kHz
TX Power Variation vs. Temperature		-	±0.5	-	dB

Table 4-6: Transmitter RF Characteristics

Note: The duty cycle of transmission at maximum output power is limited to 1%. The antenna has to be matched with a maximum VSWR of 3:1.

-

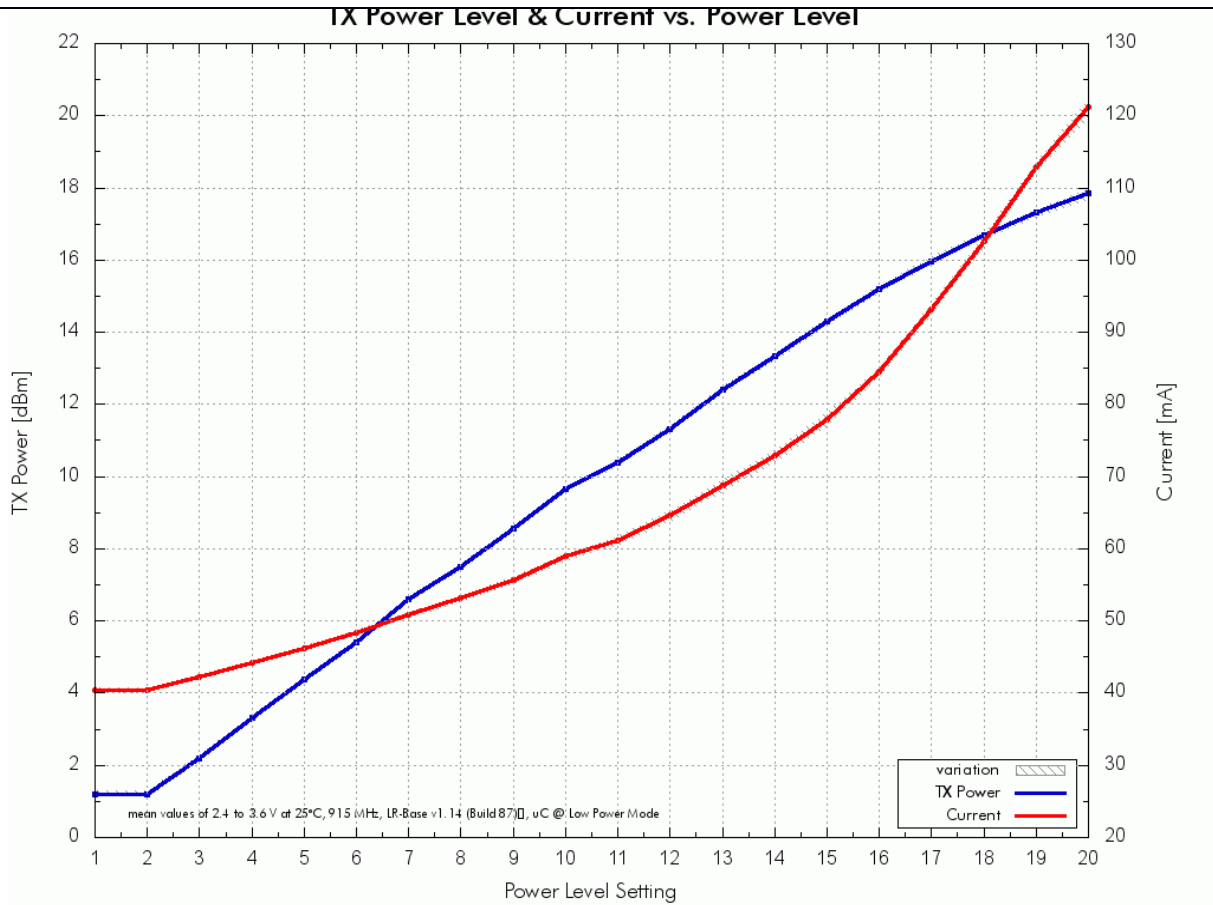

Figure4- 3: RF output power level and current consumption versus power stages from 1 to 20 @ room temperature

5. Module Package

In the following the iMAS923TH; iM980A module package is described. This description includes the iMAS923TH; iM980A pinout as well as the modules dimensions. Furthermore a recommendation for a suitable footprint is given, which should be used for further mounting on appropriate carrier boards.

5.1 Pinout Description

Figure 5 -4 depicts a description of the iMAS923TH; iM980A's pads on the bottom side. The figure shows the module with its pinout in top view (right figure). A detailed description of the individual pins can be found in Table 5 -7.

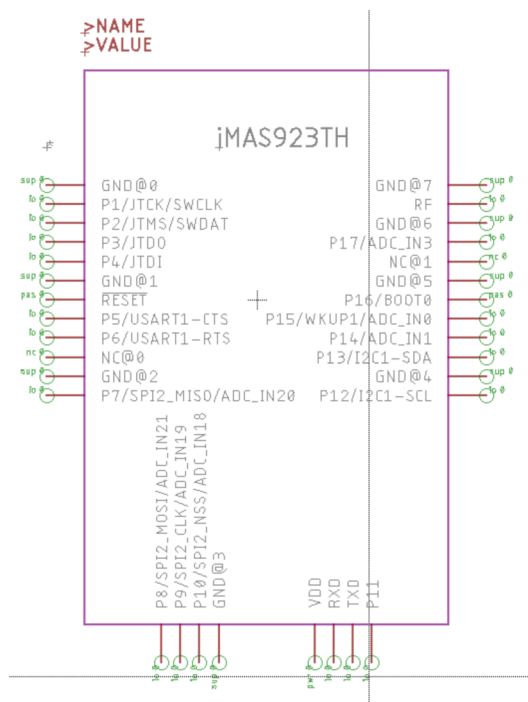

รูปที่ 5.1: iMAS923TH Pinout

Figure 5-4: Description of iMAS923TH; iM980A module pins and top view

- eMOD iMAS923TH

PIN	PIN Name	PIN Type	MCU Pin (num ber)	5 V Tolerance	Description
-----	----------	----------	----------------------------	------------------	-------------

1	GND	Supply		-	Ground connection
2	P1	D IN/OUT	PA_14 (P37)	Yes	Digital IO / JTCK / SWCLK
3	P2	D IN/OUT	PA_13 (P34)	Yes	Digital IO / JTMS / SWDIO
4	P3	D IN/OUT	PB_3 (P39)	Yes	Digital IO / JTDO
5	P4	D IN/OUT	PA_15 (P38)	Yes	Digital IO / JTDI
6	GND	Supply		-	Ground connection
7	nReset	D IN	NRST (P7)	No	NReset, internally pulled-up by 47 k Ω
8	P5	D IN/OUT	PA_11 (P32)	Yes	Digital IO / USART1-CTS
9	P6	D IN/OUT	PA_12 (P33)	Yes	Digital IO / USART1-RTS
10	NC	NC		-	Should be NC
11	GND	Supply		-	Ground connection
12	P7	D IN/OUT, A IN	PB_14 (P27)	Yes	Digital IO / SPI2_MISO / ADC_IN20
13	P8	D IN/OUT, A IN	PB_15 (P28)	Yes	Digital IO / SPI2_MOSI / ADC_IN21
14	P9	D IN/OUT, A IN	PB_13 (P26)	Yes	Digital IO / SPI2_CLK / ADC_IN19
15	P10	D IN/OUT, A IN	PB_12 (P25)	Yes	Digital IO / SPI2_NSS / ADC_IN18
16	GND	Supply		-	Ground connection
17	VDD	Supply		-	Supply voltage
18	RxD	D IN/OUT	PA_10 (P31) PB_6 (P42)	Yes	Digital IO / USART1-RX
19	TxD	D IN/OUT	PA_9 (P30)	Yes	Digital IO / USART1-TX
20	P11	D IN/OUT	PA_8	Yes	Digital IO

			(P29)		
21	P12	D IN/OUT	PB_8 (P45)	Yes	Digital IO / I2C1-SCL
22	GND	Supply		-	Ground connection
23	P13	D IN/OUT	PB_9 (P46)	Yes	Digital IO / I2C1-SDA
24	P14	D IN/OUT, A IN	PA_1 (P11)	Yes	Digital IO / ADC_IN1
25	P15	D IN/OUT, A_IN	PA_0 (P10)	Yes	Digital IO / WKUP1 / ADC_IN0
26	P16	D IN	BOOT0 (P44)	No	Bootloader Pin 0, internally pulled-down by 47 k Ω
27	GND	Supply		-	Ground connection
28	NC	NC		-	This pin should be left unconnected
29	P17	D IN/OUT, A IN	PA_3 (P13)	No	Digital IO / ADC_IN3
30	GND	Supply		-	Ground connection
31	RF	A IN/OUT		-	External 50 Ω port for monostatic antenna connection
32	GND	Supply		-	Ground connection

Table 5- 7: iMAS923TH; iM980A Pinout Table

5.2 Module Dimensions

The outer dimensions of the iMAS923TH; iM980A are given by Figure 5-5 and Figure 5-6.

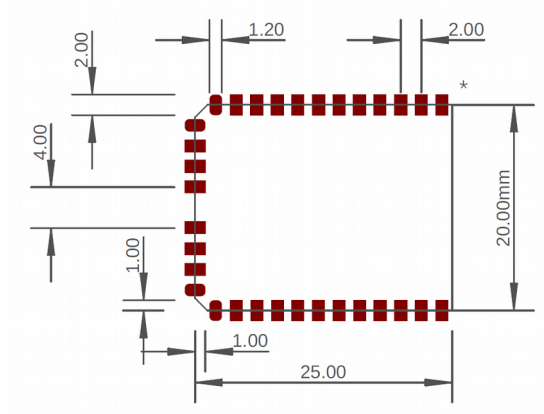

Figure5-5: Outer Dimensions of the iMAS923TH; iM980A (top view)

5.3 Recommended Footprint

According to Chapter 5.2, a recommendation for the footprint of the iMAS923TH; iM980A is given by Figure 5-6.

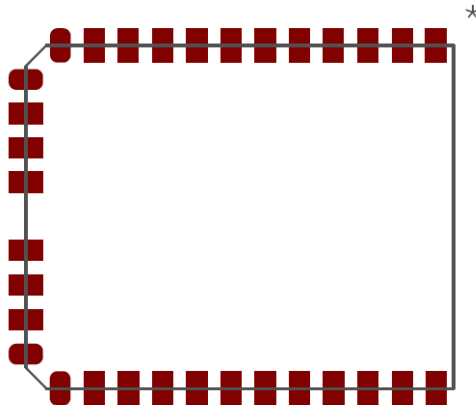

Figure5-6: Recommended footprint of the iMAS923TH; iM980A (top view)

-

6. Module Interface Characteristics

6.1 Programming Interface

For programming the module with special firmware versions, there are two types of interfaces supported: A SWD-interface, which require a special programmer, as well as a bootloader-interface, for updating the modules firmware via UART-interface.

Note: The module offers some IOs that are connected to the JTAG On-chip Debug system. Currently this interface is unavailable¹.

¹ Currently there is a silicon limitation for the MCU of the module. For more information please see:
http://www.st.com/resource/en/errata_sheet/dm00097022.pdf (ES0224, V7.0, chapter 2.1.2)

7. Integration Guide

The iMAS923TH; iM980A provides 32 connectors as described in Chapter 5. For integrating the iMAS923TH; iM980A into an environment, a typically circuit as given in Chapter 7.1 can be used. While designing the PCB Layout, the recommendations of Chapter 7.2 should be applied, as well as the recommendation for soldering in Chapter 7.3.

7.1 Typical Application Schematic

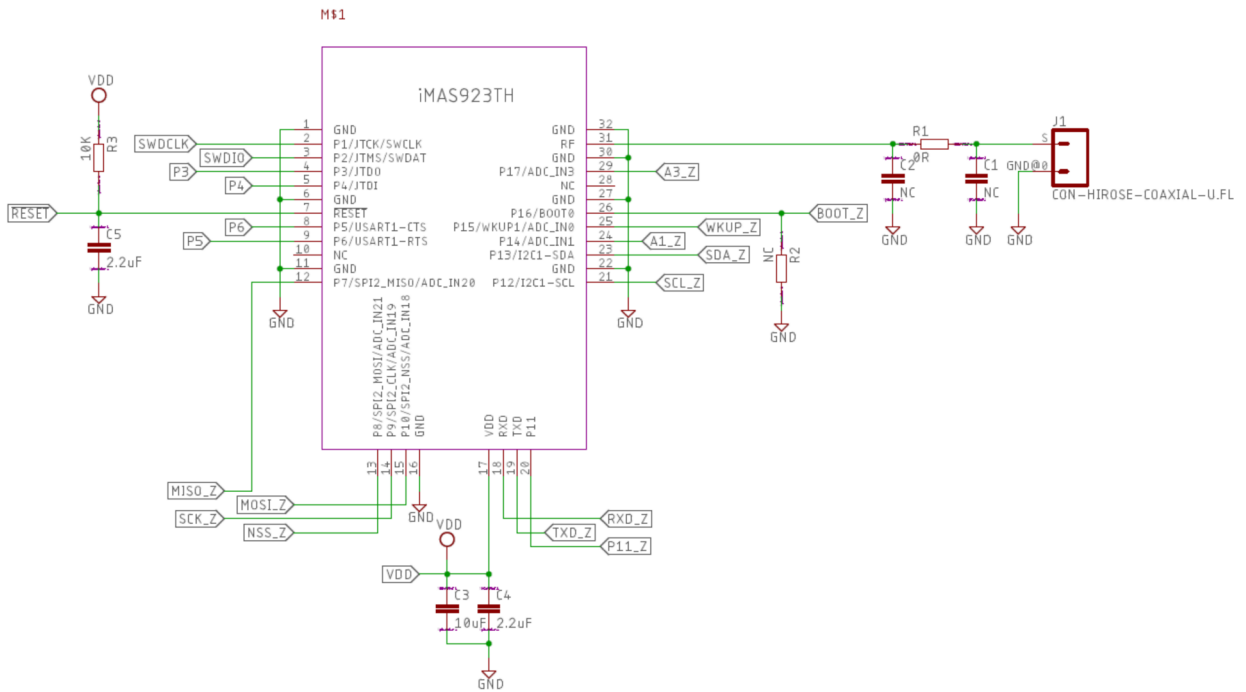

Figure 7.1:

Figure 7-7: Typical Application Schematic for iMAS923TH; iM980A

7.2 PCB Design Recommendation

The Top Layer of the carrier board should be kept free of Tracks and Vias under the iMAS923TH; iM980A because there are some test pads on the bottom side of the module which are not covered by solder resist.

All GND pads of the module should be connected via low impedance path to GND.

The iMAS923TH; iM980A's RF interface is already matched to 50 Ω . By using an adequate 50 Ω antenna, no additional matching components are required¹. For an ideal signal transmission between the modules RF pad and the antenna, the transmission line should be as short as possible and represent an impedance of 50 Ω .

Note: Disregarding this recommendation can affect the RF performance respective RF output power, sensitivity, and unwanted emissions.

This impedance depends on frequency and PCB structure. It is recommended to use a grounded coplanar waveguide (CPWG) structure, to reduce effects of electromagnetic fields. The impedance of transmission line for grounded CPWG is basically affected by height H and material of the substrate, gap G between transmission line and ground on the top layer, as well as width W and thickness T of the transmission lines (Figure 7 -8).

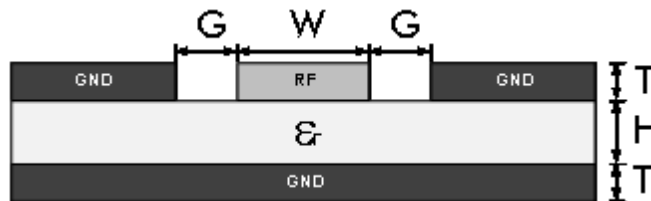

Figure7-8: Structure of a grounded CPWG

¹In other case a special matching network is required

Assuming a frequency of approx. 923 MHz, FR4 ($\epsilon_r \approx 4.8$) as substrate material, copper as conductor material, G = 0.54 mm and T = 35 μ m, the width of transmission line is given by Table 7-8.

H [mm]	W [mm]
1.0	1.465
1.6	2.0

Table7-8: Recommended width of transmission line for CPWG and 923MHz

7.3 Recommended Soldering Conditions

An example of the temperature profile for the soldering process of the iMAS923TH; iM980A is depicted in Figure 7-9 with the corresponding values as given by Table 7-9. The temperature values should not exceed the limits.

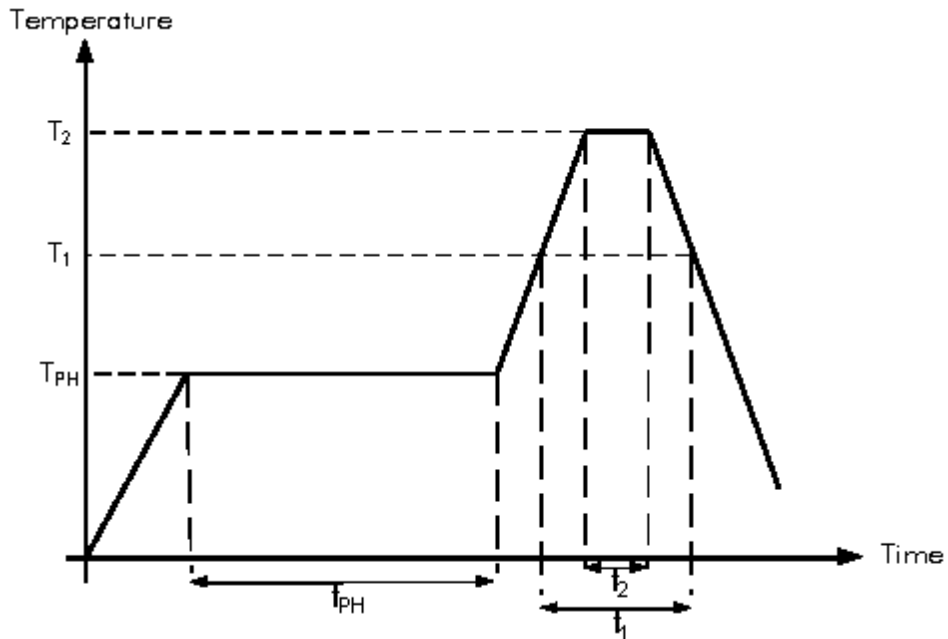

Figure7-9: Soldering Profile

Phase	Pb-Free Conditions
Preheating	$t_{PH} = 120s$ $T_{PH} = 160\sim 180^{\circ}C$
Primary heat	$t_1 = 60s$ $T_1 = 220^{\circ}C$
Peak	$t_2 = 10s$ (max) $T_2 = 255^{\circ}C$

Table7-9: Recommended Soldering Parameter for Temperature and Timing

Note: The quality of the soldering process depends on several parameters, e.g. soldering paste, carrier board design, fabrication equipment,...

8. Ordering Information

Ordering Part Number	Description	Distributor
iMAS923TH; iM980A	Radio Module 128 KB Flash, 32 KB RAM, 32 MHz MCU crystal	sales@emone.co.th
SCLORA001AS923TH – iMAS923TH; iM980A	Arduino Adapter Board with iMAS923TH; iM980A	sales@emone.co.th

Table8- 10: Ordering Information

9. Appendix

9.1 List of Abbreviations

ADC Analog-to-Digital Converter

BER Bit Error Rate

BSC Basic Spacing between Centers

CPWG Coplanar Waveguide

CW Continuous Wave

GND Ground

GPIO General Purpose Input/Output

I²C Inter-Integrated Circuit

MCU Microcontroller Unit

PCB Printed Circuit Board

RAM Random Access Memory

RF Radio Frequency

SMBus System Management Bus

SMT [Surface Mounted Technology](#)

SPI Serial Peripheral Interface

TRX Transceiver

USB Universal Serial Bus

9.2 List of Figures

.....	Figure 1-1: Picture of iMAS923TH	iv
.....	Figure 2-2: Block Diagram of Radio Module iMAS923TH	vi
.....	Figure 4-3: RF output power level and current consumption versus power stages from 1 to 20 @ room temperature	xv
.....	Figure 5-4: Description of iMAS923TH module pins and top view	xvii
.....	Figure 5-5: Outer Dimensions of the iMAS923TH (top view)	xxi
.....	Figure 5-6: Recommended footprint of the iMAS923TH (top view)	xxi
.....	Figure 7-7: Typical Application Schematic for iMAS923TH	xxiii
.....	Figure 7-8: Structure of a grounded CPWG	xxiv
.....	Figure 7-9: Soldering Profile	xxv
.....	Table 2-1: Typically Radio Performance of iMAS923TH	vi
.....	Table 3-2: Data Rates and Spreading Factors	ix
.....	Table 4-3: Absolute Maximum Ratings	x
.....	Table 4-4: General Characteristics	xii
.....	Table 4-5: Module Interface Characteristics	xiii

- Table 4-6: Transmitter RF Characteristicsxiv

- Table 5-7: iMAS923TH Pinout Tablexx

- Table 7-8: Recommended width of transmission line for CPWG and 923MHzxxv

- Table 7-9: Recommended Soldering Parameter for Temperature and Timingxxvi

- Table 8-10: Ordering Informationxxvi

[1] Semtech Sx1272 Data Sheet from www.semtech.com

[2] LoRaWAN_Regional_Parameters from www.lora-alliance.org

10. Regulatory Compliance Information

The iMAS923TH; iM980A module has received Federal Communications Commission (FCC) CFR47 Telecommunications, Part 15 Subpart C modular approval in accordance with Part 15.212 Modular Transmitter Statement about FCC.

10.1 FCC Regulatory Notices

Modification Statement

EmOne has not approved any changes or modifications to this device by the user. Any changes or modifications could void the user's authority to operate the equipment.

Interference Statement

This device complies with Part 15 of the FCC Rules. Operation is subject to the following two conditions: (1) this device may not cause interference, and (2) this device must accept any interference, including interference that may cause undesired operation of the device.

Wireless notice

This equipment complies with FCC radiation exposure limits set forth for an uncontrolled environment. The antenna should be installed and operated with minimum distance of 20 cm between the radiator and your body. This transmitter must not be co-located or operating in conjunction with any other antenna or transmitter.

Permitted Antenna

This radio transmitter iMAS923TH (iM980a) has been approved by FCC to operate with the antenna types listed below with the maximum permissible gain indicated. Antenna types not included in this list, having a gain greater than the maximum gain indicated for that type, are strictly prohibited for use with this device.

Type	Max Gain
Planar inverted F-antenna ¹	4 dB

¹Please refer to the Mote II data sheet for further information.

FCC Class B Digital Device Notice

This equipment has been tested and found to comply with the limits for a Class B digital device, pursuant to part 15 of the FCC Rules. These limits are designed to provide reasonable protection against harmful interference in a residential installation. This equipment generates, uses and can radiate radio frequency energy and, if not installed and used in accordance with the instructions, may cause harmful interference to radio communications. However, there is no guarantee that interference will not occur in a particular installation. If this equipment does cause harmful interference to radio or television reception, which can be determined by turning the equipment off and on, the user is encouraged to try to correct the interference by one or more of the following measures:

- Reorient or relocate the receiving antenna.
- Increase the separation between the equipment and receiver.
- Connect the equipment into an outlet on a circuit different from that to which the receiver is connected.
- Consult the dealer or an experienced radio/TV technician for help.

Labelling Requirements for Host Device

The host device shall be properly labelled to identify the modules within the host device. The certification label of the module shall be clearly visible at all times when installed in the host device, otherwise the host device must be labelled to display the FCC ID of the module, preceded by the words "Contains transmitter module", or the word "Contains", or similar wording expressing the same meaning, as follows:

Contains FCC ID: **N/A**

The applicable regulation requirements are subject to change. EmOne does not take any responsibility for the correctness and accuracy of the aforementioned information. National laws and regulations, as well as their interpretation can vary with the country. In case of uncertainty, it is recommended to contact either EmOne's accredited Test Center or to consult the local authorities of the relevant countries.

11. Important Notice

11.1 Disclaimer

EmOne points out that all information in this document is given on an “as is” basis. No guarantee, neither explicit nor implicit is given for the correctness at the time of publication. EmOne reserves all rights to make corrections, modifications, enhancements, and other changes to its products and services at any time and to discontinue any product or service without prior notice. It is recommended for customers to refer to the latest relevant information before placing orders and to verify that such information is current and complete. All products are sold and delivered subject to “General Terms and Conditions” of EmOne, supplied at the time of order acknowledgment.

EmOne assumes no liability for the use of its products and does not grant any licenses for its patent rights or for any other of its intellectual property rights or third-party rights. It is the customer’s duty to bear responsibility for compliance of systems or units in which products from EmOne are integrated with applicable legal regulations. Customers should provide adequate design and operating safeguards to minimize the risks associated with customer products and applications. The products are not approved for use in life supporting systems or other systems whose malfunction could result in personal injury to the user. Customers using the products within such applications do so at their own risk.

Any reproduction of information in datasheets of EmOne is permissible only if reproduction is without alteration and is accompanied by all given associated warranties, conditions, limitations, and notices. Any resale of EmOne products or services with statements different from or beyond the parameters stated by EmOne for that product/solution or service is not allowed and voids all express and any implied warranties. The limitations on liability in favor of EmOne shall also affect its employees, executive personnel and bodies in the same way. EmOne is not responsible or liable for any such wrong statements.

Copyright © 2018, EmOne

11.2 Contact Information

EmOne (Thailand) Co.,Ltd.

39/1 Soi. Sangkhom Songkhro 12

Lat Phrao, Bangkok 10230 Thailand

T +66 9 8585 1280

F +66 2 040 2220

E sales@emone.co.th

I www.emone.co.th